



XHEZ.F-A-1103 Through-penetration Firestop Systems

[Page Bottom](#)

Design/System/Construction/Assembly Usage Disclaimer

- Authorities Having Jurisdiction should be consulted in all cases as to the particular requirements covering the installation and use of UL Listed or Classified products, equipment, system, devices, and materials.
 - Authorities Having Jurisdiction should be consulted before construction.
 - Fire resistance assemblies and products are developed by the design submitter and have been investigated by UL for compliance with applicable requirements. The published information cannot always address every construction nuance encountered in the field.
 - When field issues arise, it is recommended the first contact for assistance be the technical service staff provided by the product manufacturer noted for the design. Users of fire resistance assemblies are advised to consult the general Guide Information for each product category and each group of assemblies. The Guide Information includes specifics concerning alternate materials and alternate methods of construction.
 - Only products which bear UL's Mark are considered as Classified, Listed, or Recognized.
-

Through-penetration Firestop Systems

[See General Information for Through-penetration Firestop Systems](#)

System No. F-A-1103

August 19, 2009

F Rating — 2 Hr

T Rating — 3/4 Hr

L Rating At Ambient — Less Than 1 CFM/sq ft

L Rating At 400°F — Less Than 1 CFM/sq ft

W Rating — Class 1

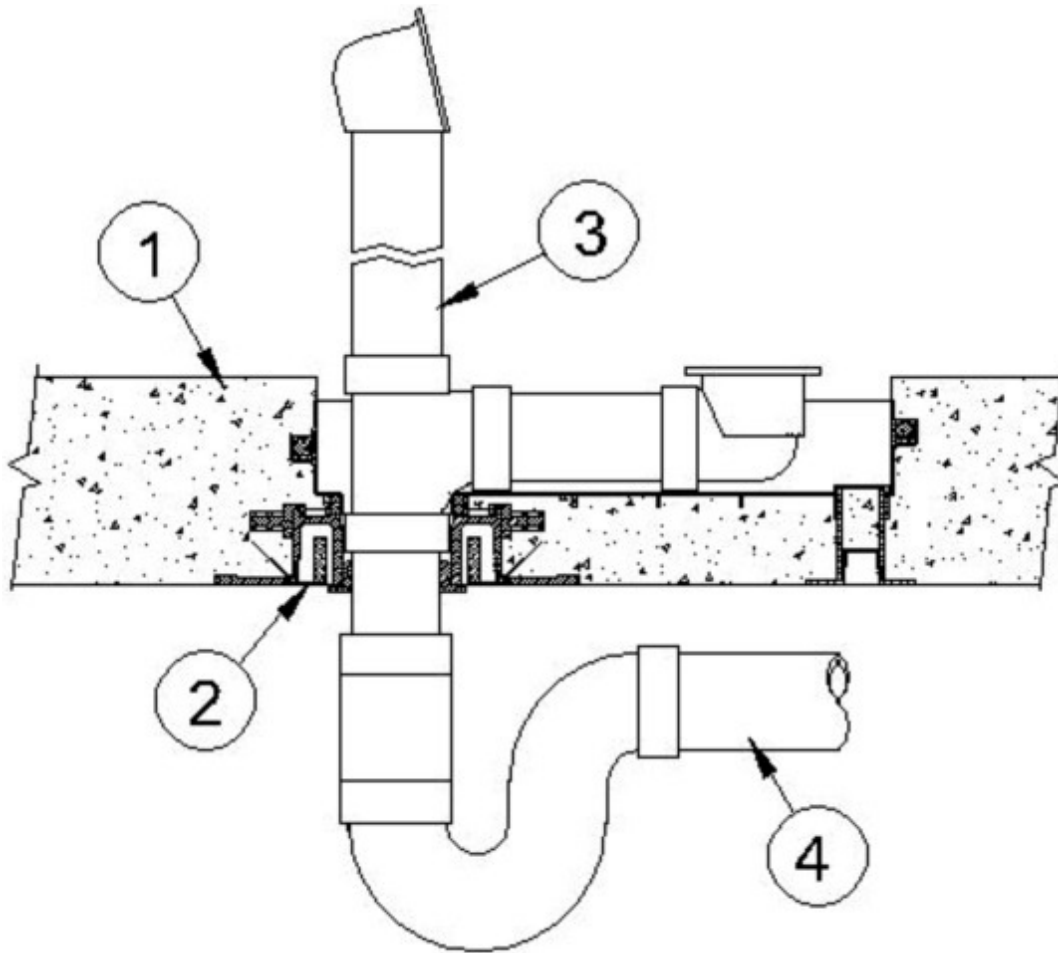

1. **Floor Assembly** — Min 4-1/2 in. (114 mm) thick reinforced lightweight or normal weight (100-150 pcf or 1600-2400 kg/m³) concrete.

2. **Firestop Device* - Tub Box** — Nom 12-1/2 in. (318 mm) long by 2 in. (51 mm) deep nonmetallic tub box with adjustable legs and intumescent coupling. Cast in place firestop device attached to form and permanently embedded during concrete placement or grouted in concrete assembly in accordance with accompanying installation instructions. Min concrete thickness of 2 in. (51 mm) shall be maintained below tub box.

SECURUS INC, DBA HUBBARD ENTERPRISES — HydroFlame PS-TB-200

3. **Waste/Overflow Fitting** — Nom 1-1/2 in. (38 mm) diam brass waste/overflow fitting with chromed brass drain tube inserted through base of tub box. Drain tube of waste/overflow fitting secured in top or bottom of tub box base using drain seal bushing supplied with firestop device.

4. **Drain Piping** — Nom 1-1/2 in. (38 mm) or 2 in. (51 mm) diam cast iron or copper drain piping with the appropriate fittings/bushings for connection to the waste/overflow fitting. Drain piping rigidly supported away from tub box with suitable hangers.

*Bearing the UL Classification Mark

Last Updated on 2009-08-19

Questions?

Notice of Disclaimer

Page Top

Copyright © 2009 Underwriters Laboratories Inc.®

The appearance of a company's name or product in this database does not in itself assure that products so identified have been manufactured under UL's Follow-Up Service. Only those products bearing the UL Mark should be considered to be Listed and covered under UL's Follow-Up Service. Always look for the Mark on the product.

UL permits the reproduction of the material contained in the Online Certification Directory subject to the following conditions: 1. The Guide Information, Designs and/or Listings (files) must be presented in their entirety and in a non-misleading manner, without any manipulation of the data (or drawings). 2. The statement "Reprinted from the Online Certifications Directory with permission from Underwriters Laboratories Inc." must appear adjacent to the extracted material. In addition, the reprinted material must include a copyright notice in the following format: "Copyright © 2009 Underwriters Laboratories Inc.®"

An independent organization working for a safer world with integrity, precision and knowledge.

