



XHEZ.F-A-2190 Through-penetration Firestop Systems

Page Bottom

Design/System/Construction/Assembly Usage Disclaimer

- Authorities Having Jurisdiction should be consulted in all cases as to the particular requirements covering the installation and use of UL Listed or Classified products, equipment, system, devices, and materials.
 - Authorities Having Jurisdiction should be consulted before construction.
 - Fire resistance assemblies and products are developed by the design submitter and have been investigated by UL for compliance with applicable requirements. The published information cannot always address every construction nuance encountered in the field.
 - When field issues arise, it is recommended the first contact for assistance be the technical service staff provided by the product manufacturer noted for the design. Users of fire resistance assemblies are advised to consult the general Guide Information for each product category and each group of assemblies. The Guide Information includes specifics concerning alternate materials and alternate methods of construction.
 - Only products which bear UL's Mark are considered as Classified, Listed, or Recognized.
-

Through-penetration Firestop Systems

[See General Information for Through-penetration Firestop Systems](#)

System No. F-A-2190

August 19, 2009

F Rating — 3 Hr

T Rating — 0 Hr

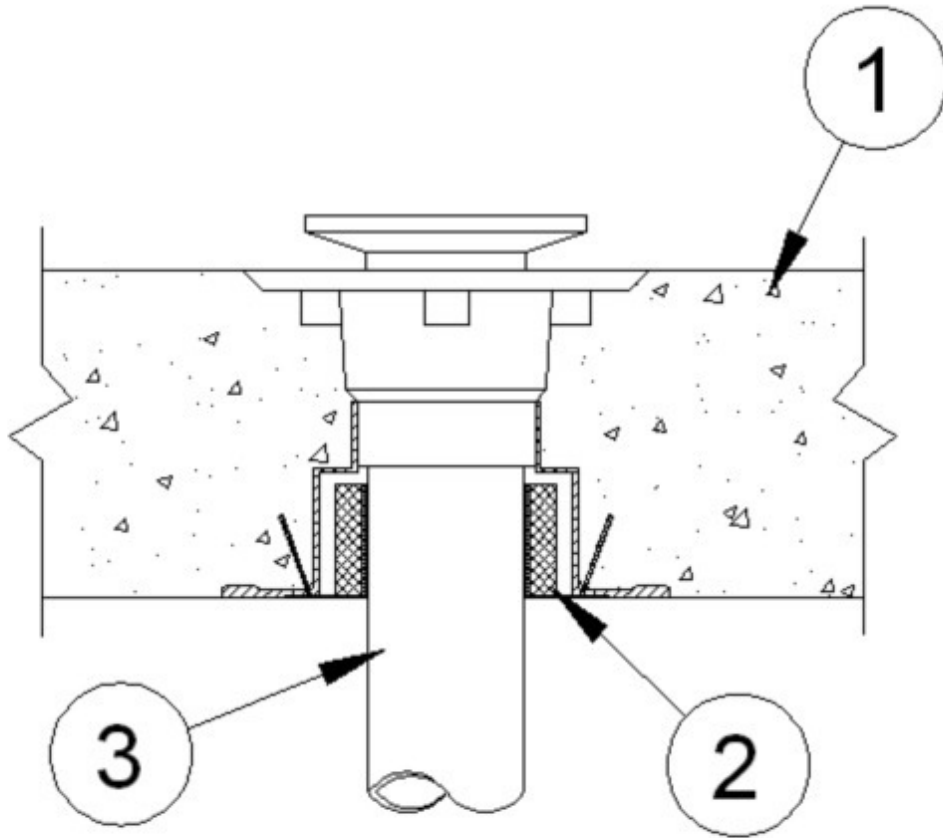

1. **Floor Assembly** — Min 5 in. (127 mm) thick lightweight or normal weight (100-150 pcf or 1600-2400 kg/m³) concrete floor assembly.

2. **Firestop Device* - Shower/Floor Drain** — Cast in place firestop device with polished brass or chromed steel shower drain or floor drain strainer attached to form and permanently embedded during concrete placement in accordance with accompanying installation instructions.

SECURUS INC, DBA HUBBARD ENTERPRISES — HydroFlame PS-SD

3. **Drain Piping** — Nom 2 in. (51 mm) diam Schedule 40 PVC drain piping cemented into bottom socket of firestop device. Different drain pipe types (cast iron, ABS, copper, etc.) can be connected to the shower drain base by cementing a short piece of PVC pipe into the bottom of the shower drain base so it extends min 2 in. (51 mm) below the floor and then using the appropriate fittings/bushings to adapt to these types of drain pipe. When the tail piece of the shower drain assembly extends below the slab, cement or compression fittings/bushings can be used to adapt to the different drain pipe types. Drain piping rigidly supported at underside of floor with suitable hangers.

*Bearing the UL Classification Mark

Last Updated on 2009-08-19

[Questions?](#)

[Notice of Disclaimer](#)

[Page Top](#)

Copyright © 2009 Underwriters Laboratories Inc.®

The appearance of a company's name or product in this database does not in itself assure that products so identified have been manufactured under UL's Follow-Up Service. Only those products bearing the UL Mark should be considered to be Listed and covered under UL's Follow-Up Service. Always look for the Mark on the product.

UL permits the reproduction of the material contained in the Online Certification Directory subject to the following conditions: 1. The Guide Information, Designs and/or Listings (files) must be presented in their entirety and in a non-misleading manner, without any manipulation of the data (or drawings). 2. The statement "Reprinted from the Online Certifications Directory with permission from Underwriters Laboratories Inc." must appear adjacent to the extracted material. In addition, the reprinted material must include a copyright notice in the following format: "Copyright © 2009 Underwriters Laboratories Inc.®"

An independent organization working for a safer world with integrity, precision and knowledge.

